



## Internal Combustion Engine Counterbalance Trucks

# H50 – H80

Capacity 5.0 t – 8.0 t | Series 396-04

**DIESEL** **HVO**

### Sustainable performance

- Hydrostatic drive, twin pedal and Linde Load Control for efficient handling of heavy goods
- The Linde torsion support in combination with high-mounted tilt cylinders ensures safer and faster load handling, especially at high lifting heights
- Improved visibility thanks to slimline, nested mast profiles
- Extended service intervals thanks to hydrostatic transmission – no gearbox, no clutch, no differential or drum brakes
- Wireless data transmission for smooth integration into software systems, e.g. for fleet management

# STANDARD AND OPTIONAL EQUIPMENT

	Manufacturer's type designation/equipment	H50 – H80
Workplace	Ergonomic, safe on/off access thanks to low non-slip step and grab handles on overhead guard leg and engine cover	●
	Innovative decoupling concept reducing vibrations for operator	●
	Adjustable steering column tilt	●
	Interior light	●
	12-volt power socket	●
	Comfort overhead guard for optimum headroom	●
	Operator's seat – quick, easy mechanical weight adjustment aids operator comfort	●
	Different operator's seat options: Heated seats, air suspension, active seat ventilation, fore/aft suspension	○
	Swivelling seat for easier on/off access	○
	3.5" LED colour display with steering angle and tilt angle display and Pre-Op Check	●
	7" LED multifunction colour display integrates additional functions such as cameras, Linde Safety Pilot and Pre-Op Check	○
	Cabin doors with sliding window	○
	Illuminated DIN A4 clip board	○
	Hot water heating/air conditioning with demist function and rear window heating	○
Radio incl. DAB+, MP3 player and Bluetooth hands-free kit	○	
Drive and brake system	Linde hydrostatic transmission for exceptional truck control and low fuel consumption	●
	Deutz diesel engine EU 2016/1628, stage 5 emissions	●
	DEF injection (AdBlue®), particle filter, oxidation catalytic converters, exhaust gas recirculation	●
	Engine air filter including safety element	●
	Linde Engine Protection System (LEPS) – audible warning and speed reduction in critical engine conditions	●
	Hydraulic parking brake	●
	Oversized, variable displacement hydraulic pump efficiently supplies oil to the lifting function and contributes to low fuel consumption, low noise and reduced emissions	●
	Hydraulic filter concept – hydraulic oil change after 6000 hours	●
	Power settings: Economy, Efficiency, Performance	●
Mast	Linde torsion support reduces twisting of the mast	●
	High mounted tilt cylinders reduce mast deflection	●
	Optimum visibility due to nested mast profiles on standard and triplex masts	●
	Electronic end-position cushioning with tilt stop	●
	Hydraulic pressure accumulator protects loads and increases operator comfort over rough ground	○
Attachments/ forks	Reinforced Linde forks – easy to adjust and long service life	○
	Various integrated accessories	○
	Sweeper option	○
Safety	Linde Curve Assist – automatic reduction of travel speed around corners aids stability	●
	Electrical seat belt monitoring – visual and audible feedback	●
	Linde Load Assist – increased safety at high lift heights	●
	BlueSpot and TruckSpot – visual drive path warning for pedestrians and operators	○
	Load weight indicator incl. tare function – load weight indicator including load-dependent drive and lift limitation	○
	Linde Safety Pilot – load-dependent driving and lifting speed regulation with additional functions	○
	Linde Safety Guard – visual and audible proximity warning between trucks or between trucks and pedestrians	○
Speed restriction options (via switch, indoor/outdoor, load-dependent)	○	
Digitalisation	Online data transmission	●
	WiFi data transmission	○
	Linde Fleet Management (local and cloud-based fleet management with various modules)	○
	Linde Pre-Op Check – customisable daily inspection log to check the readiness of the truck for operation, integrated in the truck display	○
Axles and tyres	Super-elastic (SE) tyres	●
	High performance closed shoulder tyres CS20	○
	Pneumatic tyres	○
	Anti-static tyres, non-marking	○
	Dirt deflectors/mud guards, front and rear	○
Operation/load handling	Twin pedal control – smooth acceleration and quick reversing	●
	Single pedal control – smooth acceleration and fast manoeuvring	○
	Linde Load Control – central control lever fully integrated into the armrest for precise control of all hydraulic functions	●
	Individual lever control of working hydraulics, levers mounted on armrest	○

● Standard equipment      ○ Optional equipment

\*EPA/CARB Stage 4 Final

# LOAD CAPACITY

## H50/600

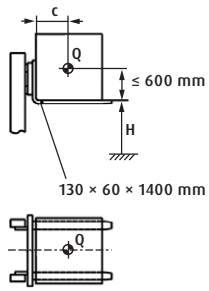

H (mm)	Q (kg)				
10000	1200	1100	1030	960	
9600	1740	1610	1490	1400	
9200	2280	2110	1960	1830	
8800	2820	2610	2430	2270	
8600	3100	2860	2660	2490	
8400	3370	3110	2890	2710	
8200	3640	3360	3130	2920	
8000	3910	3610	3360	3140	
7800	4180	3870	3600	3360	
7600	4450	4120	3830	3580	
7400	4720	4370	4060	3800	
$\leq 7200$	5000	4620	4300	4010	
<b>c (mm)</b>	400-600	700	800	900	

## H60/600

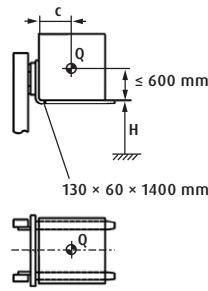

H (mm)	Q (kg)				
10000	1700	1570	1460	1360	
9600	2270	2100	1950	1820	
9200	2840	2630	2440	2280	
8800	3420	3160	2940	2740	
8400	3990	3690	3430	3210	
8200	4280	3950	3680	3440	
8000	4560	4220	3920	3670	
7800	4850	4480	4170	3900	
7600	5140	4750	4420	4130	
7400	5420	5010	4660	4360	
7200	5710	5280	4910	4590	
$\leq 7000$	6000	5540	5160	4820	
<b>c (mm)</b>	400-600	700	800	900	

## H70/600

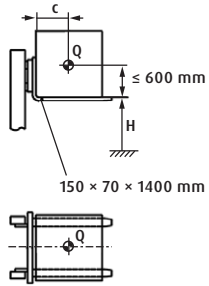

H (mm)	Q (kg)				
10000	2800	2590	2410	2250	
9600	3400	3140	2920	2730	
9200	4000	3700	3440	3220	
8800	4600	4250	3960	3700	
8600	4900	4530	4210	3940	
8400	5200	4810	4470	4180	
8200	5500	5080	4730	4420	
8000	5800	5360	4990	4670	
7800	6100	5640	5250	4910	
7600	6400	5920	5510	5150	
7400	6700	6200	5760	5390	
$\leq 7200$	7000	6470	6020	5630	
<b>c (mm)</b>	400-600	700	800	900	

## H80/600

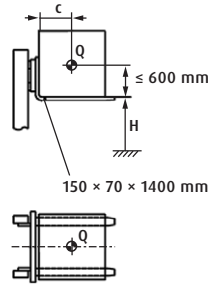

H (mm)	Q (kg)				
10000	3200	2960	2750	2570	
9600	3880	3590	3340	3120	
9200	4570	4230	3930	3680	
8800	5250	4860	4520	4230	
8600	5600	5180	4820	4500	
8400	5940	5490	5110	4780	
8200	6280	5810	5410	5060	
8000	6620	6130	5700	5330	
7800	6970	6450	6000	5610	
7600	7310	6760	6290	5880	
7400	7650	7080	6590	6160	
$\leq 7200$	8000	7400	6880	6440	
<b>c (mm)</b>	400-600	700	800	900	

## H80/900

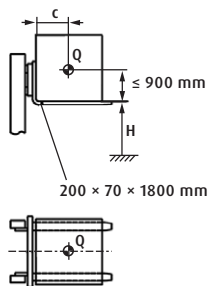

H (mm)	Q (kg)				
10000	3000	2820	2660	2510	
9600	3660	3440	3250	3070	
9200	4330	4070	3840	3630	
8800	5000	4700	4430	4190	
8400	5660	5320	5020	4750	
8200	6000	5640	5320	5030	
8000	6330	5950	5610	5310	
7800	6660	6260	5910	5590	
7600	7000	6580	6200	5870	
7400	7330	6890	6500	6150	
7200	7660	7200	6800	6430	
$\leq 7000$	8000	7520	7090	6710	
<b>c (mm)</b>	600-900	1000	1100	1200	

## H80/1100

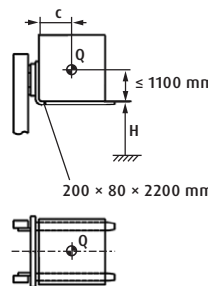

H (mm)	Q (kg)				
10000	3000	2840	2690	2560	
9600	3640	3450	3270	3110	
9200	4290	4060	3850	3670	
8800	4930	4670	4430	4220	
8400	5580	5280	5010	4770	
8000	6220	5890	5590	5320	
7800	6540	6200	5880	5600	
7600	6870	6500	6170	5870	
7400	7190	6810	6460	6150	
7200	7510	7110	6750	6430	
7000	7830	7420	7040	6700	
$\leq 6900$	8000	7570	7190	6840	
<b>c (mm)</b>	900-1100	1200	1300	1400	

H = Lifting height, c = Load centre distance, Q = Load capacity  
Load capacity for standard mast and fork carriage

# TECHNICAL DATA (according to VDI 2198)

	TECHNICAL DATA (according to VDI 2198)					
	1.1	Manufacturer (abbreviation)	Linde MH	Linde MH	Linde MH	
Characteristics	1.2	<b>Manufacturer's type designation</b>	<b>H50 D</b>	<b>H60 D</b>	<b>H70 D</b>	
	1.2a	Series	396-04	396-04	396-04	
	1.3	Drive	Diesel	Diesel	Diesel	
	1.4	Operation	Seated	Seated	Seated	
	1.5	Rated capacity/rated load	Q (t)	5.0	6.0	7.0
	1.6	Load centre distance	c (mm)	600	600	600
	1.8	Load distance, centre of drive axle to fork	x (mm)	629.5	629.5	639.5
	1.9	Wheelbase	y (mm)	2200	2200	2200
	Weight	2.1	Service weight	kg	10101	10165
2.2		Axle loading, laden front/rear	kg	12694/2407	14254/1911	16004/2374
2.3		Axle loading, unladen front/rear	kg	4900/5201	4901/5264	5060/6318
Tyres/chassis	3.1	Tyres: solid rubber, superelastic, pneumatic, polyurethane	SE	SE	SE tw.	
	3.2	Tyre size, front	355/65-15	355/65-15	8.25-15	
	3.3	Tyre size, rear	8.25-15	8.25-15	315/70-15 (300-15)	
	3.5	Wheels, number front/rear (x = driven wheels)	2x/2	2x/2	4x/2	
	3.6	Tread, front	b10 (mm)	1594	1594	1742
	3.7	Tread, rear	b11 (mm)	1600	1600	1550
	Dimensions	4.1	Mast/fork carriage tilt, forward/backward	$\alpha/\beta$ (°)	5.0/9.0	5.0/9.0
4.2		Mast height, lowered	h1 (mm)	2735 <sup>1)</sup>	2735 <sup>1)</sup>	2738 <sup>1)</sup>
4.3		Free lift	h2 (mm)	150	150	150
4.4		Lift	h3 (mm)	3550	3550	3150
4.5		Mast height, extended	h4 (mm)	4448	4448	4245
4.7		Height of overhead guard (cabin)	h6 (mm)	2746	2746	2748
4.8		Seat height relating to SIP/stand height	h7 (mm)	1507	1507	1509
4.12		Coupling height	h10 (mm)	830	830	830
4.19		Overall length	l1 (mm)	4719	4719	4729
4.20		Length to fork face	l2 (mm)	3519	3519	3529
4.21		Overall width	b1/b2 (mm)	1900/1870 <sup>2)</sup>	1900/1870 <sup>2)</sup>	2232/1870 <sup>2)</sup>
4.22		Fork dimensions DIN ISO 2331	s/e/l (mm)	60 × 130 × 1200	60 × 130 × 1200	70 × 150 × 1200
4.23		Fork carriage to ISO 2328, class/type A, B		4A	4A	4A
4.24		Fork carriage width	b3 (mm)	1800	1800	1800
4.31		Ground clearance, laden, below mast	m1 (mm)	208	204	208
4.32		Ground clearance, centre of wheelbase	m2 (mm)	250	249	251
4.33		Load dimensions b12 × l6	b12 × l6 (mm)	-	-	-
4.34		Aisle width predetermined load dimensions	Ast (mm)	-	-	-
4.34.1		Aisle width for pallets 1000 × 1200 crossways	Ast (mm)	5016 <sup>3)</sup>	5016 <sup>3)</sup>	5026 <sup>3)</sup>
4.34.2		Aisle width for pallets 800 × 1200 lengthways	Ast (mm)	5216 <sup>3)</sup>	5216 <sup>3)</sup>	5226 <sup>3)</sup>
4.35	Turning radius	Wa (mm)	3186	3186	3186	
4.36	Inside turning radius	b13 (mm)	1061	1061	1061	
Performance	5.1	Travel speed, laden/unladen	km/h	23/23	23/23	23/23
	5.2	Lifting speed, laden/unladen	m/s	0.54/0.54	0.54/0.54	0.49/0.53
	5.3	Lowering speed, laden/unladen	m/s	0.54/0.5	0.54/0.5	0.56/0.45
	5.5	Drawbar pull, laden/unladen	N	50000/35000	50000/35000	50000/37000
	5.7	Gradeability, laden/unladen	%	32.0/36.0	30.0/36.0	28.0/35.0
	5.9	Acceleration time, laden/unladen	s	5.4/4.8	5.6/5.0	5.7/5.1
	5.10	Service brake		hydrostatic	hydrostatic	hydrostatic
Combustion-engine	7.1	Engine manufacturer/type		Deutz TCD 4.1 L4	Deutz TCD 4.1 L4	Deutz TCD 4.1 L4
	7.2	Engine power according to ISO 1585	kW	85	85	85
	7.3	Rated speed	min-1	2200	2200	2200
	7.4	Number of cylinders/displacement	(-)/(cm <sup>3</sup> )	4/4038	4/4038	4/4038
	7.5	Fuel consumption according to DIN EN 16796	l/h	5 <sup>4)</sup>	5.3 <sup>4)</sup>	5.8 <sup>4)</sup>
	7.5.1	CO <sub>2</sub> equivalent according to DIN EN 16796	kg/h	15.9	16.8	18.4
	7.6	Turnover output according to VDI 2198	t/h	365.0	440.0	517.0
7.7	Turnover efficiency according to VDI 2198	t/l	39.7	44.4	48.3	
Drive	8.1	Type of drive unit		hydrost./stepl.	hydrost./stepl.	hydrost./stepl.
Additional data	10.1	Operating pressure for attachments	bar	265	265	265
	10.2	Oil flow for attachments	l/min	95	95	95
	10.7	Sound pressure level LpAZ (at the operator's seat)	dB(A)	77	77	77
	10.8	Towing coupling, type DIN 15170		similar DIN 15170-H	similar DIN 15170-H	similar DIN 15170-H
	11.2	Stability		1.86	1.57	1.6

1) With 150 mm free lift

2) Front/rear

3) Incl. a = 200 mm safety distance

4) Energy consumption at 45 work cycles per hour

Characteristics	1.1	Manufacturer (abbreviation)		Linde MH	Linde MH	Linde MH
	1.2	<b>Manufacturer's type designation</b>		<b>H80 D</b>	<b>H80/900 D</b>	<b>H80/1100 D</b>
	1.2a	Series		396-04	396-04	396-04
	1.3	Drive		Diesel	Diesel	Diesel
	1.4	Operation		Seated	Seated	Seated
	1.5	Rated capacity/rated load	Q (t)	8.0	8.0	8.0
	1.6	Load centre distance	c (mm)	600	900	1100
	1.8	Load distance, centre of drive axle to fork	x (mm)	639.5	669.5	679.5
	1.9	Wheelbase	y (mm)	2200	2510	2810
Weight	2.1	Service weight	kg	12333	14054	14838
	2.2	Axle loading, laden front/rear	kg	17852/2481	19756/2298	20561/2277
	2.3	Axle loading, unladen front/rear	kg	5345/6988	6754/7300	7495/7343
Tyres/chassis	3.1	Tyres: solid rubber, superelastic, pneumatic, polyurethane		SE tw.	SE tw.	SE tw.
	3.2	Tyre size, front		8.25-15	8.25-15	315/70-15 (300-15)
	3.3	Tyre size, rear		315/70-15 (300-15)	315/70-15 (300-15)	315/70-15 (300-15)
	3.5	Wheels, number front/rear (x = driven wheels)		4x/2	4x/2	4x/2
	3.6	Tread, front	b10 (mm)	1742	1742	1752
	3.7	Tread, rear	b11 (mm)	1550	1550	1550
	Dimensions	4.1	Mast/fork carriage tilt, forward/backward	$\alpha/\beta$ (°)	5.0/9.0	5.0/9.0
4.2		Mast height, lowered	h1 (mm)	2737 <sup>1)</sup>	2735 <sup>1)</sup>	2737 <sup>1)</sup>
4.3		Free lift	h2 (mm)	150	150	150
4.4		Lift	h3 (mm)	3150	2750	2750
4.5		Mast height, extended	h4 (mm)	4244	4144	4146
4.7		Height of overhead guard (cabin)	h6 (mm)	2746	2746	2747
4.8		Seat height relating to SIP/stand height	h7 (mm)	1508	1507	1508
4.12		Coupling height	h10 (mm)	828	828	827
4.19		Overall length	l1 (mm)	4729	5629	6339
4.20		Length to fork face	l2 (mm)	3529	3829	4139
4.21		Overall width	b1/b2 (mm)	2232/1870 <sup>3)</sup>	2232/1870 <sup>3)</sup>	2305/1870 <sup>3)</sup>
4.22		Fork dimensions DIN ISO 2331	s/e/l (mm)	70 × 150 × 1200	70 × 200 × 1800	80 × 200 × 2200
4.23		Fork carriage to ISO 2328, class/type A, B		4A	4A	4A
4.24		Fork carriage width	b3 (mm)	2180	2180	2400
4.31		Ground clearance, laden, below mast	m1 (mm)	204	201	208
4.32		Ground clearance, centre of wheelbase	m2 (mm)	250	248	250
4.33		Load dimensions b12 × l6	b12 × l6 (mm)	-	2000 × 1800	2000 × 2200
4.34		Aisle width predetermined load dimensions	Ast (mm)	-	6180	6930
4.34.1		Aisle width for pallets 1000 × 1200 crossways	Ast (mm)	5026 <sup>3)</sup>	5380 <sup>3)</sup>	5730 <sup>3)</sup>
4.34.2		Aisle width for pallets 800 × 1200 lengthways	Ast (mm)	5226 <sup>3)</sup>	5580 <sup>3)</sup>	5930 <sup>3)</sup>
4.35	Turning radius	Wa (mm)	3186	3510	3850	
4.36	Inside turning radius	b13 (mm)	1061	1240	1410	
Performance	5.1	Travel speed, laden/unladen	km/h	23/23	23/23	23/23
	5.2	Lifting speed, laden/unladen	m/s	0.49/0.53	0.49/0.53	0.49/0.53
	5.3	Lowering speed, laden/unladen	m/s	0.56/0.45	0.56/0.45	0.56/0.45
	5.5	Drawbar pull, laden/unladen	N	51000/41000	52000/46000	54000/50000
	5.7	Gradeability, laden/unladen	%	26.0/34.0	24.0/34.0	23.0/34.0
	5.9	Acceleration time, laden/unladen	s	5.8/5.2	6.0/5.2	6.1/5.3
	5.10	Service brake		hydrostatic	hydrostatic	hydrostatic
Combustion-engine	7.1	Engine manufacturer/type		Deutz TCD 4.1 L4	Deutz TCD 4.1 L4	Deutz TCD 4.1 L4
	7.2	Engine power according to ISO 1585	kW	85	85	85
	7.3	Rated speed	min-1	2200	2200	2200
	7.4	Number of cylinders/displacement	(-)/(cm <sup>3</sup> )	4/4038	4/4038	4/4038
	7.5	Fuel consumption according to DIN EN 16796	l/h	6 <sup>4)</sup>	6 <sup>4)</sup>	6.1 <sup>4)</sup>
	7.5.1	CO <sub>2</sub> equivalent according to DIN EN 16796	kg/h	19.1	19.1	19.4
	7.6	Turnover output according to VDI 2198	t/h	594.0	590.0	586.0
7.7	Turnover efficiency according to VDI 2198	t/l	51.7	51.3	51	
Drive	8.1	Type of drive unit		hydrost./stepl.	hydrost./stepl.	hydrost./stepl.
Additional data	10.1	Operating pressure for attachments	bar	265	265	265
	10.2	Oil flow for attachments	l/min	95	95	95
	10.7	Sound pressure level LpAZ (at the operator's seat)	dB(A)	77	77	77
	10.8	Towing coupling, type DIN 15170		similar DIN 15170-H	similar DIN 15170-H	similar DIN 15170-H
	11.2	Stability		1.55	1.46	1.45

1) With 150 mm free lift

2) Front/rear

3) Incl. a = 200 mm safety distance

4) Energy consumption at 45 work cycles per hour

# MAST TABLES

## STANDARD MAST (in mm)

Series	195							
Lift	h3: 3550	h3: 3850	h3: 4150	h3: 4550	h3: 4850	h3: 5250	h3: 6050	
Height measurements	h1: 2735 h2: 150 h4: 4448	h1: 2885 h2: 150 h4: 4748	h1: 3035 h2: 150 h4: 5048	h1: 3235 h2: 150 h4: 5448	h1: 3385 h2: 150 h4: 5748	h1: 3585 h2: 150 h4: 6148	h1: 3985 h2: 150 h4: 6948	
Manufacturer's type designation								
H50	<input type="radio"/>	<input type="radio"/>	<input type="radio"/>	<input type="radio"/>	<input type="radio"/>	<input type="radio"/>	<input type="radio"/>	
H60	<input type="radio"/>	<input type="radio"/>	<input type="radio"/>	<input type="radio"/>	<input type="radio"/>	<input type="radio"/>	<input type="radio"/>	

Series	195							
Lift	h3: 3150	h3: 3450	h3: 3750	h3: 4150	h3: 4450	h3: 4850	h3: 5650	
Height measurements	h1: 2735 h2: 150 h4: 4243	h1: 2885 h2: 150 h4: 4543	h1: 3035 h2: 150 h4: 4843	h1: 3235 h2: 150 h4: 5243	h1: 3385 h2: 150 h4: 5543	h1: 3585 h2: 150 h4: 5943	h1: 3985 h2: 150 h4: 6743	
Manufacturer's type designation								
H70	<input type="radio"/>	<input type="radio"/>	<input type="radio"/>	<input type="radio"/>	<input type="radio"/>	<input type="radio"/>	<input type="radio"/>	
H80	<input type="radio"/>	<input type="radio"/>	<input type="radio"/>	<input type="radio"/>	<input type="radio"/>	<input type="radio"/>	<input type="radio"/>	

Series	195							
Lift	h3: 2750	h3: 3050	h3: 3350	h3: 3750	h3: 4050	h3: 4450	h3: 5250	
Height measurements	h1: 2735 h2: 150 h4: 4145	h1: 2885 h2: 150 h4: 4445	h1: 3035 h2: 150 h4: 4745	h1: 3235 h2: 150 h4: 5145	h1: 3385 h2: 150 h4: 5445	h1: 3585 h2: 150 h4: 5845	h1: 3985 h2: 150 h4: 6645	
Manufacturer's type designation								
H80/900	<input type="radio"/>	<input type="radio"/>	<input type="radio"/>	<input type="radio"/>	<input type="radio"/>	<input type="radio"/>	<input type="radio"/>	
H80/1100	<input type="radio"/>	<input type="radio"/>	<input type="radio"/>	<input type="radio"/>	<input type="radio"/>	<input type="radio"/>	<input type="radio"/>	

## TRIPLEX MAST (in mm)

Series	195							
Lift	h3: 4770	h3: 5370	h3: 5820	h3: 6420	h3: 4705	h3: 5155	h3: 5605	
Height measurements	h1: 2712 h2: 1755 h4: 5662	h1: 2862 h2: 1905 h4: 6262	h1: 3012 h2: 2055 h4: 6712	h1: 3212 h2: 2255 h4: 7312	h1: 2708 h2: 1555 h4: 5793	h1: 2858 h2: 1705 h4: 6243	h1: 3008 h2: 1855 h4: 6693	
Manufacturer's type designation								
H50	<input type="radio"/>	<input type="radio"/>	<input type="radio"/>	<input type="radio"/>	–	–	–	
H60	<input type="radio"/>	<input type="radio"/>	<input type="radio"/>	<input type="radio"/>	–	–	–	
H70	–	–	–	–	<input type="radio"/>	<input type="radio"/>	<input type="radio"/>	
H80	–	–	–	–	<input type="radio"/>	<input type="radio"/>	<input type="radio"/>	

Series	195	
Lift	h3: 6205	h3: 7255
Height measurements	h1: 3208 h2: 2055 h4: 7293	h1: 3558 h2: 2405 h4: 8343
Manufacturer's type designation		
H50	–	–
H60	–	–
H70	<input type="radio"/>	<input type="radio"/>
H80	<input type="radio"/>	<input type="radio"/>

Series	195							
Lift	h3: 3955	h3: 4405	h3: 4855	h3: 5455	h3: 5905	h3: 7105	h3: 7705	
Height measurements	h1: 2712 h2: 1255 h4: 5347	h1: 2862 h2: 1405 h4: 5797	h1: 3012 h2: 1555 h4: 6247	h1: 3212 h2: 1755 h4: 6847	h1: 3362 h2: 1905 h4: 7297	h1: 3762 h2: 2305 h4: 8497	h1: 3962 h2: 2505 h4: 9097	
Manufacturer's type designation								
H80/900	<input type="radio"/>	<input type="radio"/>	<input type="radio"/>	<input type="radio"/>	<input type="radio"/>	<input type="radio"/>	<input type="radio"/>	
H80/1100	<input type="radio"/>	<input type="radio"/>	<input type="radio"/>	<input type="radio"/>	<input type="radio"/>	<input type="radio"/>	<input type="radio"/>	

Optional equipment

– not available

**h1:** Mast height, lowered

**h2:** Free lift

**h3:** Lift

**h4:** Mast height, extended

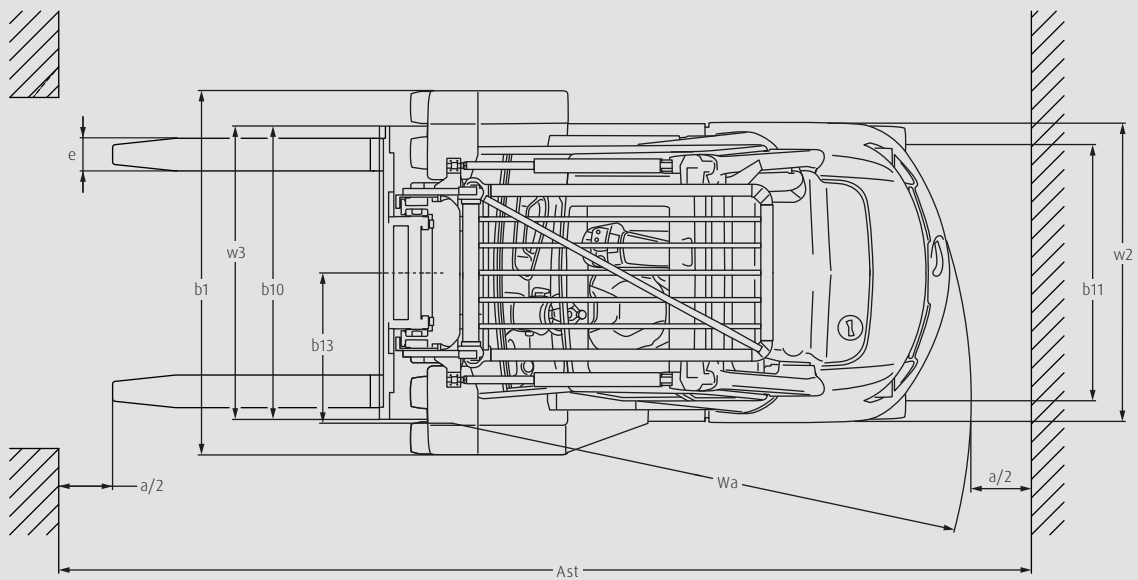
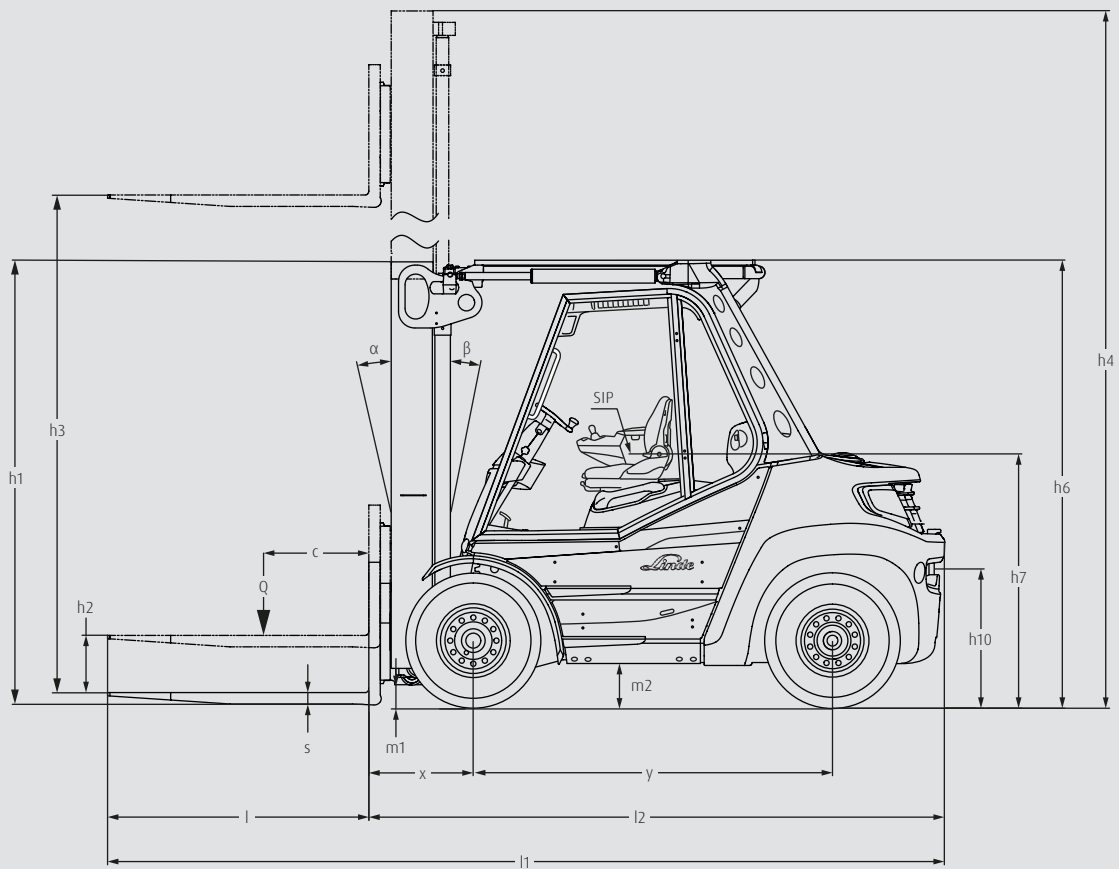

# CHARACTERISTICS



Decoupled operator's workstation

## Ergonomics

- Ergonomic and intuitive operating concept maximises forklift operator comfort
- Components decoupled from the chassis (axles, mast and tilt cylinder) protect against shocks and vibrations
- Wide range of ergonomic seats prevent posture problems
- 3.5-inch display shows steering and tilt angles as standard and provides an overview of all important information at all times



Hydraulic direct drive

## Handling

- Powerful and precise operation thanks to hydrostatic transmission
- Fast, environmentally-friendly load handling guaranteed by powerful, low fuel consumption and low emission engines
- Linde Load Control and twin pedal control guarantee precise control of all travel and mast movements
- Excellent residual capacity for stacking heavy loads



Protective overhead guard

## Safety

- Linde torsion support offers excellent stability and a 30% reduction in twisting of the mast at high lift heights
- Unparalleled operator safety thanks to Linde Protector Frame and roof protection to shield from falling loads
- Linde Curve Assist and Linde Load Assist reduce the risk of tipping and accidents during loading
- Slimline mast with nested channels for optimum all-round visibility



Engine bay

## Service

- Long maintenance intervals ensure maximum availability and minimal service costs
- Hydraulic oil change only after 6000 operating hours
- Linde hydrostatic transmission eliminates maintenance-intensive wearing parts such as clutches, gearbox and mechanical brakes
- Software updates and remote fault diagnostics enable preventive maintenance and shorten service times

Subject to modification in the interest of progress. Illustrations and technical specifications could include options and are not binding for actual constructions. All dimensions subject to usual tolerances.



**ncnielsen**

Nørregade 66, DK-7860 Balling | Tlf.: +45 99 83 83 83  
nc-nielsen.dk | info@nc-nielsen.dk