



## Pallet Stackers

# L10 – L16 B

Capacity 1.0 t – 1.6 t | Series 4596

PB

ION

### Versatile all-rounder

- Flexible, compact pedestrian pallet stacker for light to medium-duty applications in warehouses and production areas
- Versatile use in despatch areas, in support of production or when stocking shelves
- Maximum load capacity of 1.6 tonnes with lift heights up to 5.4 metres
- Five different mast types and numerous options available
- Initial lift for increased ground clearance on uneven floors or ramps
- Double-decker function for simultaneous transport of two pallets over longer distances

# MAST TABLES

## SIMPLEX MAST (in mm)

Lift	h3: 662	h3: 1462	h3: 1912
<b>Height measurements</b>	h1: 1140 <sup>3)</sup> h1#: - h2: 662 <sup>3)</sup> h4: 1140 <sup>4)</sup>	h1: 1940 h1#: - h2: 1462 <sup>3)</sup> h4: 1940 <sup>4)</sup>	h1: 2390 h1#: - h2: 1912 <sup>3)</sup> h4: 1940 <sup>4)</sup>
<b>Manufacturer's type designation</b>			
L10 B	○	○	○
L12 B	—	○	○

## STANDARD ECONOMIC MAST (in mm)

Lift	h3: 2024	h3: 2424	h3: 2924	h3: 3324
<b>Height measurements</b>	h1: 1490 h1#: 1565 h2: 150 h4: 2502 <sup>4)</sup>	h1: 1690 h1#: 1765 h2: 150 h4: 2902 <sup>4)</sup>	h1: 1940 h1#: 2015 h2: 150 h4: 3402 <sup>4)</sup>	h1: 2140 h1#: 2215 h2: 150 h4: 3827 <sup>4)</sup>
<b>Manufacturer's type designation</b>				
L10 B	○	○	○	○
L12 B	○	○	○	○

## STANDARD MAST (in mm)

Lift	h3: 2024	h3: 2424	h3: 2924	h3: 3324	h3: 3824	h3: 4224	h3: 1844	h3: 2344
<b>Height measurements</b>	h1: 1490 h1#: 1565 h2: 150 h4: 2502 <sup>4)</sup>	h1: 1690 h1#: 1765 h2: 150 h4: 2902 <sup>4)</sup>	h1: 1940 h1#: 2015 h2: 150 h4: 3402 <sup>4)</sup>	h1: 2140 h1#: 2215 h2: 150 h4: 3827 <sup>4)</sup>	h1: 2390 h1#: 2465 h2: 150 h4: 4302 <sup>4)</sup>	h1: 2590 <sup>2)</sup> h1#: 2665 h2: 150 h4: 4702 <sup>4)</sup>	h1: 1415 h1#: 1490 h2: 150 h4: 2364 <sup>7)</sup>	h1: 1665 h1#: 1740 h2: 150 h4: 2864 <sup>7)</sup>
<b>Manufacturer's type designation</b>								
L10 B	○	○	○	○	○	○	—	—
L12 B	○	○	○	○	○	○	—	—
L14 B	—	—	—	—	—	—	○	○
L16 B	—	—	—	—	—	—	○	○

Lift	h3: 2844	h3: 3244	h3: 3744	h3: 4144	h3: 4644
<b>Height measurements</b>	h1: 1915 h1#: 1990 h2: 150 h4: 3364 <sup>7)</sup>	h1: 2115 h1#: 2190 h2: 150 h4: 3764 <sup>7)</sup>	h1: 2365 h1#: 2440 h2: 150 h4: 4264 <sup>7)</sup>	h1: 2565 <sup>5)</sup> h1#: 2640 h2: 150 h4: 4664 <sup>7)</sup>	h1: 2815 <sup>5)</sup> h1#: 2890 h2: 150 h4: 5164 <sup>7)</sup>
<b>Manufacturer's type designation</b>					
L10 B	—	—	—	—	—
L12 B	—	—	—	—	—
L14 B	○	○	○	○	○
L16 B	○	○	○	○	○

## DUPLEX MAST (in mm)

Lift	h3: 2024	h3: 2424	h3: 2924	h3: 3324	h3: 3824	h3: 4224	h3: 1844	h3: 2344
<b>Height measurements</b>	h1: 1490 h1#: - h2: 1012 <sup>3)</sup> h4: 2502 <sup>4)</sup>	h1: 1690 h1#: - h2: 1212 <sup>3)</sup> h4: 2902 <sup>4)</sup>	h1: 1940 h1#: - h2: 1462 <sup>3)</sup> h4: 3402 <sup>4)</sup>	h1: 2140 h1#: - h2: 1662 <sup>3)</sup> h4: 3827 <sup>4)</sup>	h1: 2390 h1#: - h2: 1912 <sup>3)</sup> h4: 4302 <sup>4)</sup>	h1: 2590 <sup>2)</sup> h1#: - h2: 2112 <sup>3)</sup> h4: 4702 <sup>4)</sup>	h1: 1415 h1#: - h2: 895 <sup>4)</sup> h4: 2364 <sup>7)</sup>	h1: 1665 h1#: - h2: 1145 <sup>4)</sup> h4: 2864 <sup>7)</sup>
<b>Manufacturer's type designation</b>								
L10 B	—	—	—	—	—	—	—	—
L12 B	—	—	—	—	—	—	—	—
L14 B	○	○	○	○	○	○	○	○
L16 B	○	○	○	○	○	○	○	○

Lift	h3: 2844	h3: 3244	h3: 3744	h3: 4144
<b>Height measurements</b>	h1: 1915 h1#: - h2: 1395 <sup>4)</sup> h4: 3364 <sup>7)</sup>	h1: 2115 h1#: - h2: 1595 <sup>4)</sup> h4: 3764 <sup>7)</sup>	h1: 2365 h1#: - h2: 1845 <sup>4)</sup> h4: 4264 <sup>7)</sup>	h1: 2565 <sup>5)</sup> h1#: - h2: 2045 <sup>4)</sup> h4: 4664 <sup>7)</sup>
<b>Manufacturer's type designation</b>				
L10 B	—	—	—	—
L12 B	—	—	—	—
L14 B	○	○	○	○
L16 B	○	○	○	○

## TRIPLEX MAST (in mm)

Lift	h3: 3636	h3: 4386	h3: 4686	h3: 3516	h3: 4266	h3: 4716	h3: 5316	h3: 5466
<b>Height measurements</b>	h1: 1690 <sup>3)</sup> h1#: - h2: 1208 h4: 4118	h1: 1940 <sup>3)</sup> h1#: - h2: 1458 h4: 4868	h1: 2040 <sup>3)</sup> h1#: - h2: 1558 h4: 5168	h1: 1665 <sup>5)</sup> h1#: - h2: 1145 <sup>4)</sup> h4: 4036 <sup>7)</sup>	h1: 1915 <sup>5)</sup> h1#: - h2: 1395 <sup>4)</sup> h4: 4786 <sup>7)</sup>	h1: 2065 <sup>5)</sup> h1#: - h2: 1545 <sup>4)</sup> h4: 5236 <sup>7)</sup>	h1: 2265 <sup>5)</sup> h1#: - h2: 1745 <sup>4)</sup> h4: 5836 <sup>7)</sup>	h1: 2315 <sup>5)</sup> h1#: - h2: 1795 <sup>4)</sup> h4: 5986 <sup>7)</sup>
<b>Manufacturer's type designation</b>								
L10 B	○	○	○	—	—	—	—	—
L12 B	○	○	○	—	—	—	—	—
L14 B	—	—	—	○	○	○	○	○
L16 B	—	—	—	○	○	○	○	○

○ Optional equipment **h1**: Mast height, lowered **h1#**: Mast height with used free lift 150 mm **h2**: Free lift **h3**: Lift **h4**: Mast height, extended

1) mast height available for L10 B only

2) only mast heights compatible with the truck optional version -D (double deck)

3) with fork carriage s=65 mm (built in); with fork carriage s=65 mm (built in) and with load backrest 800 mm over forks: -404 mm; with fork carriage s=60 mm (built out) -4 mm; with fork carriage s=55 mm (built out) and with load backrest 1000 mm over forks: -562 mm

4) with fork carriage s=65 mm (built in); with fork carriage s=65 mm (built in) and with load backrest 800 mm over forks: +404 mm; with fork carriage s=60 mm (built out) +4 mm; with fork carriage s=55 mm (built out) and with load backrest 1000 mm over forks: +562 mm

5) only mast heights compatible with the truck optional version -D (double deck)

6) with load backrest 1000 mm over forks: -562 mm

7) with load backrest 1000 mm over forks: +562 mm

# STANDARD AND OPTIONAL EQUIPMENT

Manufacturer's type designation/equipment		L10 B	L12 B	L14 B	L16 B
Safety	Active foot bumper - foot protection system	○	○	○	○
	Long tiller and low chassis skirt	●	●	●	●
	Easily accessible emergency stop button	●	●	●	●
	Warning buzzer - for operation in low noise areas	●	●	●	●
	Horn - for operation in noisy environments	○	○	○	○
	Log in PIN code	○	○	○	○
	Linde BlueSpot - visual warning of truck presence integrated into chassis contours	○	○	○	○
Service	CAN bus technology	●	●	●	●
Digitalisation	Data transmission online	○	○	○	○
	Data transmission WIFI	○	○	○	○
	Linde connect:ac pre-shift check - allows operator to report truck condition before use	○	○	○	○
	Linde connect:dt crash detection - allows electronic impact damage monitoring	○	○	○	○
Operation/load handling	Initial lift	○	○	○	○
	Double deck transport functionality	—	○	○	○
	Basic display	●	●	●	●
	Colour display	○	○	○	○
	Additional side buttons to raise and lower forks	○	○	○	○
	Soft landing of forks	●	●	●	●
	Proportional speed control - speed dependent on tiller angle	○	○	○	○
	Creep speed - for operation with tiller in vertical position	○	○	○	○
	Ergonomic tiller head with easy access to all controls	●	●	●	●
	Load backrest	○	○	○	○
	Accessory support	○	○	○	○
	Clipboard/scanner support with 24 V power supply	○	○	○	○
	Lift limit switch - 1x or 2x lift stops	○	○	○	○
	Linde Load Management Advanced	○	○	○	○
Environ- ment	Coldstore protection to -35°C (in/out)	○	○	○	○
Mast	Simplex mast	○	○	—	—
	Standard mast	○	○	○	○
	Standard economic mast	○	○	—	—
	Duplex mast	○	○	○	○
	Triplex mast	○	○	○	○
	Mast protection, polycarbonate	●	●	●	●
	Mast protection, wire mesh	○	○	○	○
Attachment/ forks	Width over forks: 520 mm	○	○	—	—
	Width over forks: 560 mm	●	●	●	●
	Fork length: 950 mm	—	—	○	○
	Fork length: 1000 mm	○	○	—	—
	Fork length: 1150 mm	●	●	●	●
Axles and tyres	Drive wheel: standard duty	●	●	●	●
	Drive wheel: heavy duty, high grip	○	○	○	○
	Drive wheel: solid rubber - for delicate floors	○	○	○	○
	Single load wheels, polyurethane	●	●	●	●
	Tandem load wheels, polyurethane	○	○	○	○
	Tandem load wheels, polyurethane greasable	○	○	○	○
Drive and brake system	Maintenance-free AC motor	●	●	●	●
	Electromagnetic braking system	●	●	●	●
	Battery compartment, vertical compact	○	○	—	—
	Battery compartment, 2 PzS-B, vertical change	○	○	○	○
	Battery compartment, 2 PzS, vertical change	—	—	○	○
Energy	Li-ION batteries - different battery capacities with front, laterally or vertically mounted opportunity charging plug	○	○	○	○
	Lead acid batteries	○	○	○	○
	On-board charger 35 A or 70 A for lead-acid and Li-ION batteries	○	○	○	○
	External chargers	○	○	○	○

● Standard equipment    ○ Optional equipment    — Not available



# TECHNICAL DATA (according to VDI 2198)

Characteristics	1.1	Manufacturer (abbreviation)		Linde MH	Linde MH	Linde MH	Linde MH
	1.2	<b>Manufacturer's type designation</b>		<b>L10 B</b>	<b>L12 B</b>	<b>L14 B</b>	<b>L16 B</b>
	1.2a	Series		4596	4596	4596	4596
	1.3	Drive		Battery	Battery	Battery	Battery
	1.4	Operation		Pedestrian	Pedestrian	Pedestrian	Pedestrian
	1.5	Rated capacity/rated load	Q (t)	1.0	1.2	1.4	1.6
	1.6	Load centre distance	c (mm)	600	600	600	600
	1.8	Load distance, centre of drive axle to fork	x (mm)	695 (707) <sup>1)2)</sup>	695 (707) <sup>1)2)</sup>	721 (688) <sup>2)</sup>	721 (688) <sup>2)</sup>
	1.9	Wheelbase	y (mm)	1123 (1204) <sup>2)3)</sup>	1123 (1204) <sup>2)3)</sup>	1237 (1272) <sup>2)2)</sup>	1237 (1272) <sup>2)2)</sup>
Weight	2.1	Service weight	kg	657	721	977	977
	2.2	Axle loading, laden front/rear	kg	558/1099	627/1294	837/1540	857/1720
	2.3	Axle loading, unladen front/rear	kg	473/184	525/196	700/277	700/277
Tyres/chassis	3.1	Tyres: solid rubber, superelastic, pneumatic, polyurethane		Polyurethane	Polyurethane	Polyurethane	Polyurethane
	3.2	Tyre size, front		Ø 230 × 75	Ø 230 × 75	Ø 230 × 75	Ø 230 × 75
	3.3	Tyre size, rear		2x Ø 85 × 85	2x Ø 85 × 85	2x Ø 85 × 85	2x Ø 85 × 85
	3.4	Additional wheels (dimensions)		Ø 140 × 54	Ø 140 × 54	Ø 140 × 54	Ø 140 × 54
	3.5	Wheels, number front/rear (X = driven wheels)		1x + 1/2	1x + 1/2	1x + 1/2	1x + 1/2
	3.6	Tread, front	b10 (mm)	516	516	516	516
	3.7	Tread, rear	b11 (mm)	380 <sup>4)</sup>	380 <sup>4)</sup>	380	380
Dimensions	4.2	Mast height, lowered	h1 (mm)	1940	1940	1915	1915
	4.3	Free lift	h2 (mm)	150	150	150	150
	4.4	Lift	h3 (mm)	2924	2924	2844	2844
	4.5	Mast height, extended	h4 (mm)	3402	3402	3364	3364
	4.6	Initial lift	h5 (mm)	- (125) <sup>5)</sup>	- (125) <sup>5)</sup>	- (125) <sup>5)</sup>	- (125) <sup>5)</sup>
	4.9	Height drawbar in operating position min./max.	h14 (mm)	856/1220 <sup>6)</sup>	856/1220 <sup>6)</sup>	856/1220 <sup>6)</sup>	856/1220 <sup>6)</sup>
	4.10	Height of wheel arms	h8 (mm)	80	80	80	80
	4.15	Height, lowered	h13 (mm)	86	86	86	86
	4.19	Overall length	l1 (mm)	1738 (1806) <sup>2)3)7)8)</sup>	1738 (1806) <sup>2)3)7)8)</sup>	1826 (1894) <sup>2)8)21)</sup>	1826 (1894) <sup>2)8)21)</sup>
	4.20	Length to fork face	l2 (mm)	588 (656) <sup>2)3)7)8)</sup>	588 (656) <sup>2)3)7)8)</sup>	676 (744) <sup>2)8)21)</sup>	676 (744) <sup>2)8)21)</sup>
	4.21	Overall width	b1/b2 (mm)	800 <sup>9)</sup>	800 <sup>9)</sup>	800 <sup>9)</sup>	800 <sup>9)</sup>
	4.22	Fork dimensions DIN ISO 2331	s/e/l (mm)	65/180/1150 <sup>10)</sup>	65/180/1150 <sup>10)20)</sup>	55/182/1150 <sup>10)20)</sup>	55/182/1150 <sup>10)20)</sup>
	4.24	Fork carriage width	b3 (mm)	533 <sup>10)</sup>	533 <sup>10)</sup>	780	780
	4.25	Fork spread	b5 (mm)	560 <sup>11)</sup>	560 <sup>11)</sup>	560	560
	4.32	Ground clearance, centre of wheelbase	m2 (mm)	27	27	27	27
4.34.1	Aisle width for pallets 1000 × 1200 crossways	Ast (mm)	2293 (2075) [2364] <sup>3)12)13)14)15)</sup>	2293 (2075) [2364] <sup>3)12)13)14)15)</sup>	2389 (2156) [2436] <sup>1)2)14)15)21)</sup>	2389 (2156) [2436] <sup>1)2)14)15)21)</sup>	
4.34.2	Aisle width for pallets 800 × 1200 lengthways	Ast (mm)	2264 (2125) [2331] <sup>3)12)13)14)15)</sup>	2264 (2125) [2331] <sup>3)12)13)14)15)</sup>	2351 (2206) [2410] <sup>1)2)14)15)21)</sup>	2351 (2206) [2410] <sup>1)2)14)15)21)</sup>	
4.35	Turning radius	Wa (mm)	1420 (1496) <sup>2)3)</sup>	1420 (1496) <sup>2)3)</sup>	1527 (1560) <sup>2)21)</sup>	1527 (1560) <sup>2)21)</sup>	
Performance	5.1	Travel speed, laden/unladen	km/h	6/6	6/6	6/6	6/6
	5.2	Lifting speed, laden/unladen	m/s	0.18/0.32 <sup>16)</sup>	0.16/0.32 <sup>16)</sup>	0.14/0.27 <sup>16)</sup>	0.13/0.27 <sup>16)</sup>
	5.3	Lowering speed, laden/unladen	m/s	0.42/0.36 <sup>17)</sup>	0.42/0.36 <sup>17)</sup>	0.42/0.27 <sup>17)</sup>	0.42/0.27 <sup>17)</sup>
	5.8	Max. gradeability, laden/unladen	%	5.0/10.0	5.0/10.0	5.0/10.0	5.0/10.0
	5.10	Service brake		Electromagnetic	Electromagnetic	Electromagnetic	Electromagnetic
Electric-engine	6.1	Drive motor rating S2 60 min	kW	1.1	1.1	1.3	1.3
	6.2	Lift motor rating at S3 15%	kW	3/11% <sup>18)</sup>	3/11% <sup>18)</sup>	3/11%	3/11%
	6.3	Battery according to DIN 43531/35/36 A, B, C, no		Li-ION compact	Li-ION compact	2PzS-B	2PzS-B
	6.4	Battery voltage/nominal capacity K5	(V)/(Ah) or kWh	24/--	24/--	24/200	24/200
	6.4a	Battery energy content	kWh	3/3.6	3/3.6	-	-
	6.5	Battery weight (±5%)	kg	21	21	195	195
	6.6	Energy consumption according to DIN EN 16796	kWh/h	0.52	0.55	0.69	0.74
	6.6.1	CO <sub>2</sub> equivalent according to DIN EN 16796	kg/h	0.3	0.3	0.4	0.4
	6.7	Turnover output according to VDI 2198	t/h	40.0	48.0	53.0	60.0
6.8	Turnover efficiency according to VDI 2198	t/kWh	42	48	45	49	
Drive/lifting mechanism	8.1	Type of drive unit		AC control	AC control	AC control	AC control
Additional data	10.7	Sound pressure level LpAZ (at the operator's seat)	dB(A)	<70	<70	<70	<70

- 1) with fork carriage  $s=65$  mm (built in); with fork carriage  $s=55$  mm (built out)  $-32$  mm for simplex mast;  $-35$  mm for standard economic, standard and duplex mast
- 2) values in paranthesis = initial lift (optional).
- 3) with compact battery compartment; with 2PzS-B battery compartment  $+55$  mm
- 4) with fork spread  $b_5=560$  mm; with  $b_5=520$  mm  $-40$  mm (not in combination with double deck option)
- 5) figures in ( ) optional
- 6) from butterfly rotation axis; in creep speed position  $+5$  mm (optional)
- 7) with fork carriage  $s=55$  mm (built out)  $+32$  mm for simplex mast;  $+35$  mm for standard economic, standard and duplex mast

- 8) with rubber bumper  $+15$  mm; with active bumper  $+23$  mm
- 9) with rubber bumper  $+21$  mm; with active bumper  $+35$  mm
- 10) with fork carriage built in; with fork carriage built out  $s=55$  mm and  $b_3=711$  mm
- 11) other fork spread available:  $b_5=520$  mm with tray 95 only and not in combination with double deck option
- 12) with tiller in the upper working position ( $10^\circ$ ) and fully turned clockwise; in creep speed position  $-12$  mm. The Ast values in brackets are calculated for special case where the swivelling range R is free.
- 13) with fork carriage  $s=65$  mm; with fork carriage  $s=55$  mm  $+15$  mm ( $+32$  for value in brackets) for simplex mast;  $+17$  mm ( $+35$  for value in brackets) for standard economic, standard and duplex mast

- 14) including a 200 mm (min.) operating aisle clearance.
- 15) [with initial lift]
- 16) with simplex and standard economic mast 0.13/0.20, with duplex mast 0.17/0.29, with triplex mast 0.17/0.28
- 17) with simplex and standard economic mast 0.23/0.23, with duplex mast 0.40/0.32, with triplex mast 0.40/0.34
- 18) for simplex and standard economic mast lift motor, rating S3 is 2.2 / 5%
- 19) with fork carriage with non deflecting forks  $s=71$  mm
- 20) with option double deck  $l+68$  mm
- 21) with 2PzS-B battery compartment; with 2PzS battery compartment  $+65$  mm

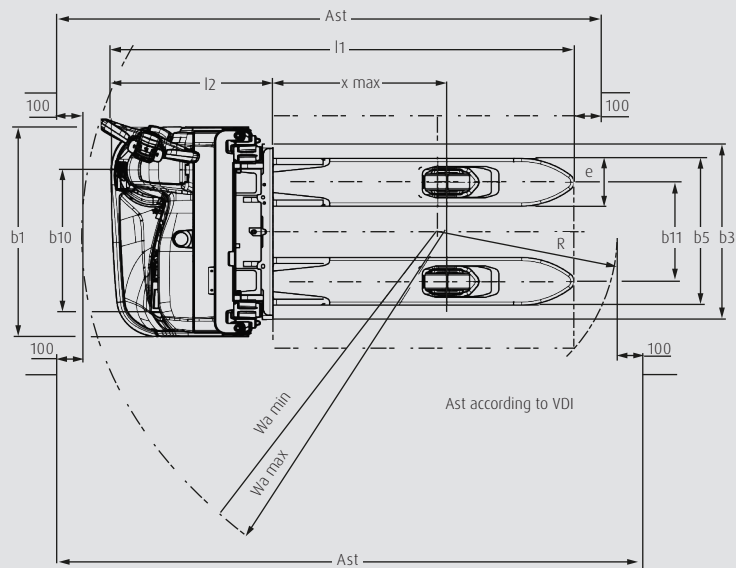
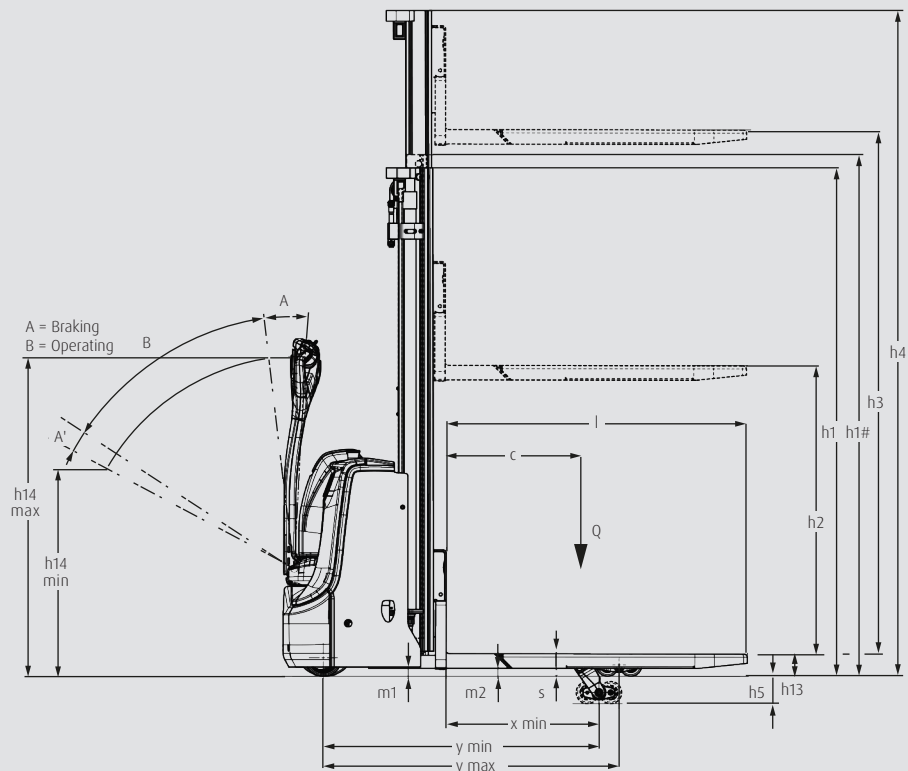

# CHARACTERISTICS



Active foot bumper (optional)

## Safety

- Long tiller arm ensures operator is at a safe distance from the truck
- Asymmetric tiller head for improved visibility of the load when stacking or transporting loads
- Low chassis skirt and active foot bumper (option) protect the operator
- Optional Linde Load Management increases safety when handling loads at height
- Optional creep speed function and Linde Safety Speed for safe manoeuvring



Ergonomic tiller head

## Ergonomics

- Ergonomic tiller head with easily accessible controls
- Easy to operate with one hand, even when wearing gloves
- Long, low-set tiller arm reduces steering effort
- Generous storage for rolls of shrink-wrap, clipboard or scanner
- Optional colour display provides information on important truck data



Precise load handling

## Handling

- Compact chassis and narrow turning radius for optimum manoeuvrability
- Speed up to 6 km/h for fast, effective work
- Powerful climbing ability even with a full pallet or double deck load
- OptiLift assistance system ensures precise load handling
- On-board charger for lead-acid and lithium-ion batteries



Easy access to truck data

## Service

- Robust design enables long service intervals
- CAN bus structure for easy access to truck data
- Low-wear components ensure high availability
- Easy access to internal components for reduced maintenance times
- Optional data transmission for remote diagnostics and software updates

Subject to modification in the interest of progress. Illustrations and technical specifications could include options and are not binding for actual constructions. All dimensions subject to usual tolerances.



**ncnielsen**

Nørregade 66, DK-7860 Balling | Tlf.: +45 99 83 83 83  
nc-nielsen.dk | info@nc-nielsen.dk