



## Pallet Trucks

# T20 – T25 AP | SP

PB

ION

H2

### Nimble all-rounder

- Compact pallet truck for efficient loading and unloading of delivery vehicles as well as transport and order picking
- Foldable operator's platform to use the vehicle as a manoeuvrable pedestrian or ride-on model (AP version)
- Unique platform concept with standing position at a 45° angle for better all-round vision and a comfortable body posture (SP version)
- Innovative Linde e-driver control concept for optimum truck handling in the 45° standing position (SP version)
- Fully suspended operator compartment reducing shocks and vibrations for smooth operation

# T20 - T25 SP

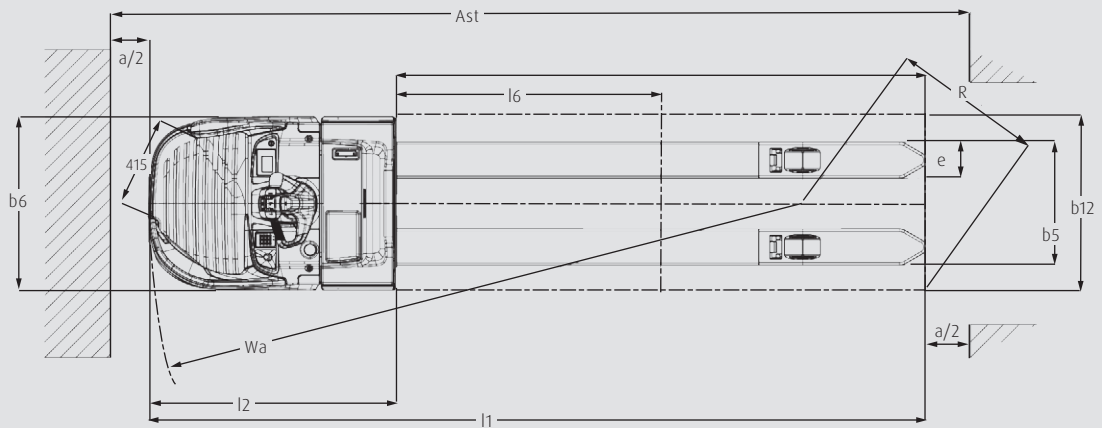
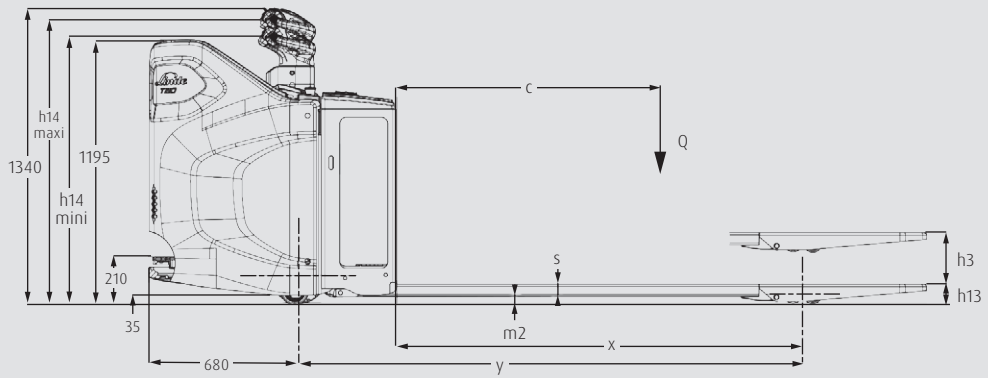

# TECHNICAL DATA (according to VDI 2198)

			Linde MH	Linde MH	Linde MH	Linde MH	
			T20 SP	T25 SP	T20 AP	T25 AP	
Characteristics	1.1	Manufacturer (abbreviation)		Linde MH	Linde MH	Linde MH	Linde MH
	1.2	Manufacturer's type designation		T20 SP	T25 SP	T20 AP	T25 AP
	1.2a	Series		1156-00	1156-00	1156-00	1156-00
	1.3	Drive		Battery	Battery	Battery	Battery
	1.4	Operation		Stand on	Stand on	Pedestrian/stand on	Pedestrian/stand on
	1.5	Rated capacity/rated load	Q (t)	2.0	2.5	2.0	2.5
	1.6	Load centre distance	c (mm)	600	1200	600	1200
	1.8	Load distance, centre of drive axle to fork	x (mm)	900/970 <sup>(2)</sup>	1762/1832 <sup>(2)</sup>	900/970 <sup>(2)</sup>	1762/1832 <sup>(2)</sup>
	1.9	Wheelbase	y (mm)	1346/1416 <sup>(2)(3)</sup>	2208/2278 <sup>(2)(3)</sup>	1346/1416 <sup>(2)(3)</sup>	2208/2278 <sup>(2)(3)</sup>
Weight	2.1	Service weight	kg	870 <sup>(4)</sup>	1010 <sup>(4)</sup>	870 <sup>(4)</sup>	1010 <sup>(4)</sup>
	2.2	Axle loading, laden front/rear	kg	1200/1670 <sup>(4)</sup>	1470/2040 <sup>(4)</sup>	1200/1670 <sup>(4)</sup>	1470/2040 <sup>(4)</sup>
	2.3	Axle loading, unladen front/rear	kg	720/150 <sup>(4)</sup>	853/157 <sup>(4)</sup>	720/150 <sup>(4)</sup>	853/157 <sup>(4)</sup>
Tyres/chassis	3.1	Tyres rubber, SE, pneumatic, polyurethane		Polyurethane	Polyurethane	Polyurethane	Polyurethane
	3.2	Tyre size, front		Ø 254 × 102	Ø 254 × 102	Ø 254 × 102	Ø 254 × 102
	3.3	Tyre size, rear		2x Ø85 × 80	2x Ø85 × 80	2x Ø85 × 80	2x Ø85 × 80
	3.4	Additional wheels (dimensions)		2x Ø 125 × 60	2x Ø 125 × 60	2x Ø 125 × 60	2x Ø 125 × 60
	3.5	Wheels, number front/rear (x = driven wheels)		1x + 2/2 (1x + 2/4) <sup>(4)</sup>	1x + 2/2 (1x + 2/4) <sup>(4)</sup>	1x + 2/2 (1x + 2/4) <sup>(4)</sup>	1x + 2/2 (1x + 2/4) <sup>(4)</sup>
	3.6	Tread, front	b10 (mm)	572 <sup>(1)</sup>	572 <sup>(1)</sup>	572 <sup>(1)</sup>	572 <sup>(1)</sup>
	3.7	Tread, rear	b11 (mm)	355/375/395/515 <sup>(1)</sup>	355/375/395/515 <sup>(1)</sup>	355/375/395/515 <sup>(1)</sup>	355/375/395/515 <sup>(1)</sup>
Dimensions	4.4	Lift	h3 (mm)	115 <sup>(1)</sup>	115 <sup>(1)</sup>	115 <sup>(1)</sup>	115 <sup>(1)</sup>
	4.9	Height drawbar in driving position min./max.	h14 (mm)	1207/1287 <sup>(1)</sup>	1207/1287 <sup>(1)</sup>	1149/1357 <sup>(1)</sup>	1149/1357 <sup>(1)</sup>
	4.15	Height, lowered	h13 (mm)	85 <sup>(7)</sup>	85 <sup>(7)</sup>	85 <sup>(7)</sup>	85 <sup>(7)</sup>
	4.19	Overall length	l1 (mm)	2276 <sup>(1)(3)</sup>	3526 <sup>(1)(3)</sup>	2249 <sup>(1)(3)</sup>	3499 <sup>(1)(3)</sup>
	4.20	Length to fork face	l2 (mm)	1126 <sup>(1)(3)</sup>	1126 <sup>(1)(3)</sup>	1099 <sup>(1)(3)</sup>	1099 <sup>(1)(3)</sup>
	4.21	Overall width	b1/b2 (mm)	790 <sup>(1)</sup>	790 <sup>(1)</sup>	790 <sup>(1)</sup>	790 <sup>(1)</sup>
	4.22	Fork dimensions DIN ISO 2331	s/e/l (mm)	55/165/1150	55/165/2400	55/165/1150	55/165/2400
	4.25	Fork spread	b5 (mm)	520/540/560/680 <sup>(1)</sup>	520/540/560/680 <sup>(1)</sup>	520/540/560/680 <sup>(1)</sup>	520/540/560/680 <sup>(1)</sup>
	4.32	Ground clearance, centre of wheelbase	m2 (mm)	30/150 <sup>(2)</sup>	30/150 <sup>(2)</sup>	30/150 <sup>(2)</sup>	30/150 <sup>(2)</sup>
	4.33	Load dimension b12 × l6	b12 × l6 (mm)	-	2x 800 × 1200	-	2x 800 × 1200
	4.34	Aisle width predetermined load dimensions	Ast (mm)	-	3841/3853 <sup>(7)(8)</sup>	-	3814/3826 <sup>(7)(8)</sup>
	4.34.1	Aisle width for pallets 1000 × 1200 crossways	Ast (mm)	2834/2897 <sup>(7)(8)</sup>	3733/3781 <sup>(7)(8)(11)</sup>	2807/2870 <sup>(7)(8)</sup>	3706/3754 <sup>(7)(8)(11)</sup>
	4.34.2	Aisle width with pallet 800 × 1200 lengthways	Ast (mm)	2726/2757 <sup>(7)(8)</sup>	-	2699/2730 <sup>(7)(8)</sup>	-
4.35	Turning radius	Wa (mm)	2026/2096 <sup>(2)(3)</sup>	2888/2958 <sup>(2)(3)</sup>	1999/2069 <sup>(2)(3)</sup>	2861/2931 <sup>(2)(3)</sup>	
Performance	5.1	Travel speed, laden/unladen	km/h	11/14 <sup>(9)(10)</sup>	11/14 <sup>(9)(10)</sup>	11/14 <sup>(9)(10)</sup>	11/14 <sup>(9)(10)</sup>
	5.2	Lifting speed, laden/unladen	m/s	0.03/0.05 <sup>(5)</sup>	0.04/0.06 <sup>(5)</sup>	0.03/0.05 <sup>(5)</sup>	0.04/0.06 <sup>(5)</sup>
	5.3	Lowering speed, laden/unladen	m/s	0.07/0.06 <sup>(5)</sup>	0.07/0.06 <sup>(5)</sup>	0.07/0.06 <sup>(5)</sup>	0.07/0.06 <sup>(5)</sup>
	5.8	Max. gradeability, laden/unladen	%	10.0/20.0	8.0/20.0	10.0/20.0	8.0/20.0
	5.9	Acceleration time, laden/unladen	s	5.9/4.6	5.9/4.6	5.9/4.6	5.9/4.6
	5.10	Service brake		Electric/hydraulic	Electric/hydraulic	Electric/hydraulic	Electric/hydraulic
Electric-engine	6.1	Drive motor rating S2 60 min	kW	3	3	3	3
	6.2	Lift motor rating at S3 15%	kW	1.2	2.2	1.2	2.2
	6.3	Battery according to DIN 43531/35/36 A,B,C,no		43 535 B/3PzS	43 535 B/3PzS	43 535 B/3PzS	43 535 B/3PzS
	6.4	Battery voltage/nominal capacity (5h)	(V)/(Ah) o. kWh	24/375	24/375	24/375	24/375
	6.5	Battery weight (±5%)	kg	327	327	327	327
	6.6	Energy consumption according to DIN EN 16796	kWh/h	0.21	0.41	0.21	0.41
	6.6.1	CO2 equivalent according to EN 16796	kg/h	0.11	0.22	0.11	0.22
	6.7	Turnover output according to VDI 2198	t/h	142.0	195.0	142.0	195.0
6.8	Turnover efficiency according to VDI 2198	t/kWh	112.0	121.0	112.0	121.0	
Additional Data	8.1	Type of drive unit		AC control	AC control	AC control	AC control
	10.7	Sound pressure level LpAZ (at the operator's seat)	dB(A)	69	69	69	69

1) (±5 mm)

2) Load arms  
upraised/lowered

3) ±0 mm = 2 PzS vertical  
or 3 PzS side change;  
+75 mm = 3 PzS vertical  
or 4 PzS side change;

+150 mm = 4 PzS vertical;  
+225 mm = 5PzS vertical.  
4) Figures with battery,  
see line 6.4/6.5

5) (±10%)  
6) Figures in parenthesis  
with tandem load wheels  
7) (0/-5 mm)

8) Including a 200 mm  
(min.) operating aisle clear-  
ance  
9) (±5%)  
10) With  
hydraulic castor wheel  
11) 2 × pallets

# TECHNICAL DATA (according to VDI 2198)

			Linde MH	Linde MH	Linde MH	Linde MH	
			T20 SP	T25 SP	T20 AP	T25 AP	
Characteristics	1.1	Manufacturer (abbreviation)		Linde MH	Linde MH	Linde MH	Linde MH
	1.2	Manufacturer's type designation		T20 SP	T25 SP	T20 AP	T25 AP
	1.2a	Series		1156-00	1156-00	1156-00	1156-00
	1.3	Drive		Battery	Battery	Battery	Battery
	1.4	Operation		Stand on	Stand on	Pedestrian/stand on	Pedestrian/stand on
	1.5	Rated capacity/rated load	Q (t)	2.0	2.5	2.0	2.5
	1.6	Load centre distance	c (mm)	600	1200	600	1200
	1.8	Load distance, centre of drive axle to fork	x (mm)	900/970 <sup>(2)</sup>	1762/1832 <sup>(2)</sup>	900/970 <sup>(2)</sup>	1762/1832 <sup>(2)</sup>
	1.9	Wheelbase	y (mm)	1346/1416 <sup>(2)(3)</sup>	2208/2278 <sup>(2)(3)</sup>	1346/1416 <sup>(2)(3)</sup>	2208/2278 <sup>(2)(3)</sup>
Weight	2.1	Service weight	kg	870 <sup>(4)(5)</sup>	1010 <sup>(4)(5)</sup>	870 <sup>(4)(5)</sup>	1010 <sup>(4)(5)</sup>
	2.2	Axle loading, laden front/rear	kg	1200/1670 <sup>(4)(5)</sup>	1470/2040 <sup>(4)(5)</sup>	1200/1670 <sup>(4)(5)</sup>	1470/2040 <sup>(4)(5)</sup>
	2.3	Axle loading, unladen front/rear	kg	720/150 <sup>(4)(5)</sup>	853/157 <sup>(4)(5)</sup>	720/150 <sup>(4)(5)</sup>	853/157 <sup>(4)(5)</sup>
Tyres/chassis	3.1	Tyres rubber, SE, pneumatic, polyurethane		Polyurethane	Polyurethane	Polyurethane	Polyurethane
	3.2	Tyre size, front		Ø 254 × 102	Ø 254 × 102	Ø 254 × 102	Ø 254 × 102
	3.3	Tyre size, rear		2x Ø85 × 80	2x Ø85 × 80	2x Ø85 × 80	2x Ø85 × 80
	3.4	Additional wheels (dimensions)		2x Ø 125 × 60	2x Ø 125 × 60	2x Ø 125 × 60	2x Ø 125 × 60
	3.5	Wheels, number front/rear (x = driven wheels)		1x + 2/2 (1x + 2/4) <sup>(6)</sup>	1x + 2/2 (1x + 2/4) <sup>(6)</sup>	1x + 2/2 (1x + 2/4) <sup>(6)</sup>	1x + 2/2 (1x + 2/4) <sup>(6)</sup>
	3.6	Tread, front	b10 (mm)	572 <sup>(7)</sup>	572 <sup>(7)</sup>	572 <sup>(7)</sup>	572 <sup>(7)</sup>
	3.7	Tread, rear	b11 (mm)	355/375/395/515 <sup>(7)</sup>	355/375/395/515 <sup>(7)</sup>	355/375/395/515 <sup>(7)</sup>	355/375/395/515 <sup>(7)</sup>
Dimensions	4.4	Lift	h3 (mm)	115 <sup>(7)</sup>	115 <sup>(7)</sup>	115 <sup>(7)</sup>	115 <sup>(7)</sup>
	4.9	Height drawbar in driving position min./max.	h14 (mm)	1207/1287 <sup>(7)</sup>	1207/1287 <sup>(7)</sup>	1149/1357 <sup>(7)</sup>	1149/1357 <sup>(7)</sup>
	4.15	Height, lowered	h13 (mm)	85 <sup>(7)</sup>	85 <sup>(7)</sup>	85 <sup>(7)</sup>	85 <sup>(7)</sup>
	4.19	Overall length	l1 (mm)	2276 <sup>(1)(3)</sup>	3526 <sup>(1)(3)</sup>	2249 <sup>(1)(3)</sup>	3499 <sup>(1)(3)</sup>
	4.20	Length to fork face	l2 (mm)	1126 <sup>(1)(3)</sup>	1126 <sup>(1)(3)</sup>	1099 <sup>(1)(3)</sup>	1099 <sup>(1)(3)</sup>
	4.21	Overall width	b1/b2 (mm)	790 <sup>(7)</sup>	790 <sup>(7)</sup>	790 <sup>(7)</sup>	790 <sup>(7)</sup>
	4.22	Fork dimensions DIN ISO 2331	s/e/l (mm)	55/165/1150	55/165/2400	55/165/1150	55/165/2400
	4.25	Fork spread	b5 (mm)	520/540/560/680 <sup>(1)</sup>	520/540/560/680 <sup>(1)</sup>	520/540/560/680 <sup>(1)</sup>	520/540/560/680 <sup>(1)</sup>
	4.32	Ground clearance, centre of wheelbase	m2 (mm)	30/150 <sup>(2)</sup>	30/150 <sup>(2)</sup>	30/150 <sup>(2)</sup>	30/150 <sup>(2)</sup>
	4.33	Load dimension b12 × l6	b12 × l6 (mm)	-	2x 800 × 1200	-	2x 800 × 1200
	4.34	Aisle width predetermined load dimensions	Ast (mm)	-	3841/3853 <sup>(2)(3)(8)</sup>	-	3814/3826 <sup>(2)(3)(8)</sup>
	4.34.1	Aisle width for pallets 1000 × 1200 crossways	Ast (mm)	2834/2897 <sup>(2)(3)(8)</sup>	3733/3781 <sup>(2)(3)(8)(11)</sup>	2807/2872 <sup>(2)(3)(8)</sup>	3706/3754 <sup>(2)(3)(8)(11)</sup>
	4.34.2	Aisle width with pallet 800 × 1200 lengthways	Ast (mm)	2726/2757 <sup>(2)(3)(8)</sup>	-	2699/2730 <sup>(2)(3)(8)</sup>	-
4.35	Turning radius	Wa (mm)	2026/2096 <sup>(2)(3)</sup>	2888/2958 <sup>(2)(3)</sup>	1999/2069 <sup>(2)(3)</sup>	2861/2931 <sup>(2)(3)</sup>	
Performance	5.1	Travel speed, laden/unladen	km/h	11/14 <sup>(9)(10)</sup>	11/14 <sup>(9)(10)</sup>	11/14 <sup>(9)(10)</sup>	11/14 <sup>(9)(10)</sup>
	5.2	Lifting speed, laden/unladen	m/s	0.03/0.05 <sup>(5)</sup>	0.04/0.06 <sup>(5)</sup>	0.03/0.05 <sup>(5)</sup>	0.04/0.06 <sup>(5)</sup>
	5.3	Lowering speed, laden/unladen	m/s	0.07/0.06 <sup>(5)</sup>	0.07/0.06 <sup>(5)</sup>	0.07/0.06 <sup>(5)</sup>	0.07/0.06 <sup>(5)</sup>
	5.8	Max. gradeability, laden/unladen	%	10.0/20.0	8.0/20.0	10.0/20.0	8.0/20.0
	5.9	Acceleration time, laden/unladen	s	5.9/4.6	5.9/4.6	5.9/4.6	5.9/4.6
	5.10	Service brake		Electric/hydraulic	Electric/hydraulic	Electric/hydraulic	Electric/hydraulic
Electric-engine	6.1	Drive motor rating S2 60 min	kW	3	3	3	3
	6.2	Lift motor rating at S3 15%	kW	1.2	2.2	1.2	2.2
	6.3	Battery according to DIN 43531/35/36 A,B,C,no		43 535 B/3PzS	43 535 B/3PzS	43 535 B/3PzS	43 535 B/3PzS
	6.4	Battery voltage/nominal capacity (5h)	(V)/(Ah) o. kWh	24/375	24/375	24/375	24/375
	6.5	Battery weight (±5%)	kg	327	327	327	327
	6.6	Energy consumption according to DIN EN 16796	kWh/h	0.21	0.41	0.21	0.41
	6.6.1	CO2 equivalent according to EN 16796	kg/h	0.11	0.22	0.11	0.22
	6.7	Turnover output according to VDI 2198	t/h	142.0	195.0	142.0	195.0
6.8	Turnover efficiency according to VDI 2198	t/kWh	112.0	121.0	112.0	121.0	
Additional Data	8.1	Type of drive unit		AC control	AC control	AC control	AC control
	10.7	Sound pressure level LpAZ (at the operator's seat)	dB(A)	69	69	69	69

1) (±5 mm)

2) Load arms upraised/ lowered

3) ±0 mm = 2 PzS vertical or 3 PzS side change; +75 mm = 3 PzS vertical or 4 PzS side change;

+150 mm = 4 PzS vertical; +225 mm = 5PzS vertical.  
4) Figures with battery, see line 6.4/6.5

5) (±10%)  
6) Figures in parenthesis with tandem load wheels  
7) (0/-5 mm)

8) Including a 200 mm (min.) operating aisle clearance  
9) (±5%)  
10) With hydraulic castor

# T20 - T25 AP

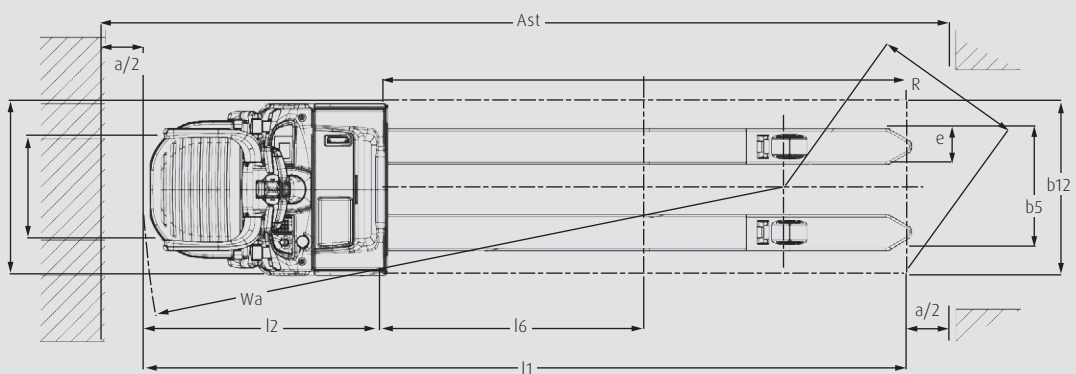
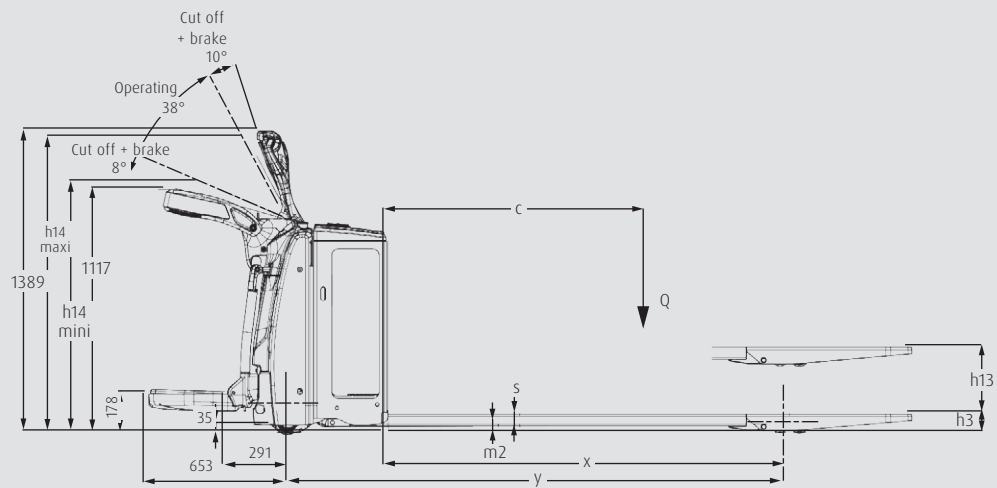

# CHARACTERISTICS



Safe 45° stand-on fixed platform



Ergonomic, height-adjustable tiller



Li-ION technology available



Foldable platform with robust sideguards

## Safety

- Automatic adjustment of operating speed when cornering to prevent risky manoeuvres
- Optional foot detection can also slow down or bring the vehicle to a smooth stop when operator's feet leave the platform (SP version)
- Fold-up side bars to protect the operator from injury in the event of collision (AP version)
- Dead man's switch and traction control for the highest possible safety in every work situation
- Software-based speed zoning with connect:zi to set up safety zones with automatic speed adjustment

## Ergonomics

- Fully decoupled operator platform for effective protection against vibrations and shocks
- Electric power steering for effortless vehicle control, including automatic steering resistance adjustment
- Unique concept with 45° operating position for optimal all-round view without straining back and neck (SP version)
- Innovative steering concept Linde e-driver for optimum, single-handed control of the vehicle in the 45° position if required (SP version)
- Automatic and gradual adjustment of vehicle speed for precise manoeuvring in tight spaces

## Handling

- High top speed of 14 km/h without load for fast transport travel
- Powerful 3 kW three-phase motor for rapid acceleration and maximum vehicle performance on inclines
- Special starting system to prevent unintentional rolling backwards on steep ground (e.g. on loading ramps)
- Mechanically sprung or hydraulic castor wheels guarantee high operating stability on uneven ground
- New generation of Li-ION batteries for more efficient energy use and optimised charging management

## Service

- Robust three-phase motor for long service intervals and low maintenance costs
- Solid construction with durable parts and sturdy chassis for maximum vehicle availability
- Effortless accessibility of all relevant components thanks to consistent design-to-service principle
- Innovative CAN bus architecture for easy access to all vehicle data via diagnostic connector
- Modern E/E architecture allows remote installation of updates and new functions

Subject to modification in the interest of progress. Illustrations and technical details could include options and are not binding for actual constructions. All dimensions subject to usual tolerances.